



# ARC • 10™ System

automated remote control System

*ARC-10* is a wireless, state-of-the-art remote control system that controls sports and recreational facilities lighting, and other electrical equipment. The components of the *ARC-10* system include Remote Control Units (RCUs), TeleDirect operating system, and ControlStation™ software.

The *ARC-10* remote control units can be controlled by ControlStation™ software from *SkyLogix*, by P & R Facilities Scheduling/Reservation software from others, via Web (Internet) access, and/or by simple touch-tone commands from any touch-tone telephone utilizing the TeleDirect™ operating system from *SkyLogix*. The *ARC-10* system sends and receives data via a sophisticated land and satellite communications infrastructure.

Now, by simply using the *ARC-10* system .... all of your sports lighting and other park facilities lighting can be easily managed and remote-controlled from one central location. Even electronic bathroom door locks, gates and irrigation/sprinklers can be controlled by the *ARC-10* system.

The *ARC-10* system replaces inaccurate photocells, timeclocks, manual switches, or more costly remote-control systems and antiquated remote-control systems. Minimize the expense and inconvenience incurred due to personnel having to visit sites to turn on/off lights and unlock/lock facility doors. Limit the wasted energy attributable to lights being turned on too early or off too late, or waste from lights left on during rainouts, cancellations, etc. Eliminate the bad publicity and reduce the liability issues resulting from failing to turn the lights on or off. Know who used the lights, when the lights were used and for how long.

## Features:

- Remote Switch-on-Demand.
- No telephone wires or other communication wires or cabling required at the *ARC-10* units.
- Multiple zone capability with independent zone control or group zone control.
- Simple dial up touch-tone control override.
- Automatically updated for changes in Daylight Savings and varying sunrise and sunset times.
- Control field/security/parking lot/restroom lighting, electronic door locks, sprinklers, etc.
- *ARC-10* can be integrated with existing Facilities Reservation or Scheduling software packages.
- Control and/or automate your sports lighting requirements from one central location.
- Delay-off and Warn-off options for safety and convenience.
- Timed-use functionality for first come, first served courts of play such as tennis or basketball.
- Sports lighting is switched on and off based on customer reservations of the facilities/fields.
- Remotely turn off the sports lighting on any one of your fields with a simple phone call from any location (cellular OK) in cases of no shows or early-terminating games.
- Remotely turn off the sports lighting on any one or all of your parks in cases of rainouts or snow-outs with one simple phone call from any location (cellular OK).
- The optional keypad control enables confirmed use of a field before the lights will turn on, whereby the user enters an access code indicating that he/she is at the site. This functionality also allows for customer light usage tracking at the unit.
- Reports showing light usage (hour metering) and lamp starts per park and per field for re-lamping and maintenance purposes.
- Reports showing light usage per user/customer for lighting billing purposes.

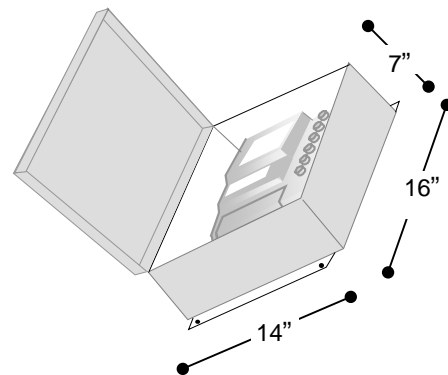

# Graphical Overview

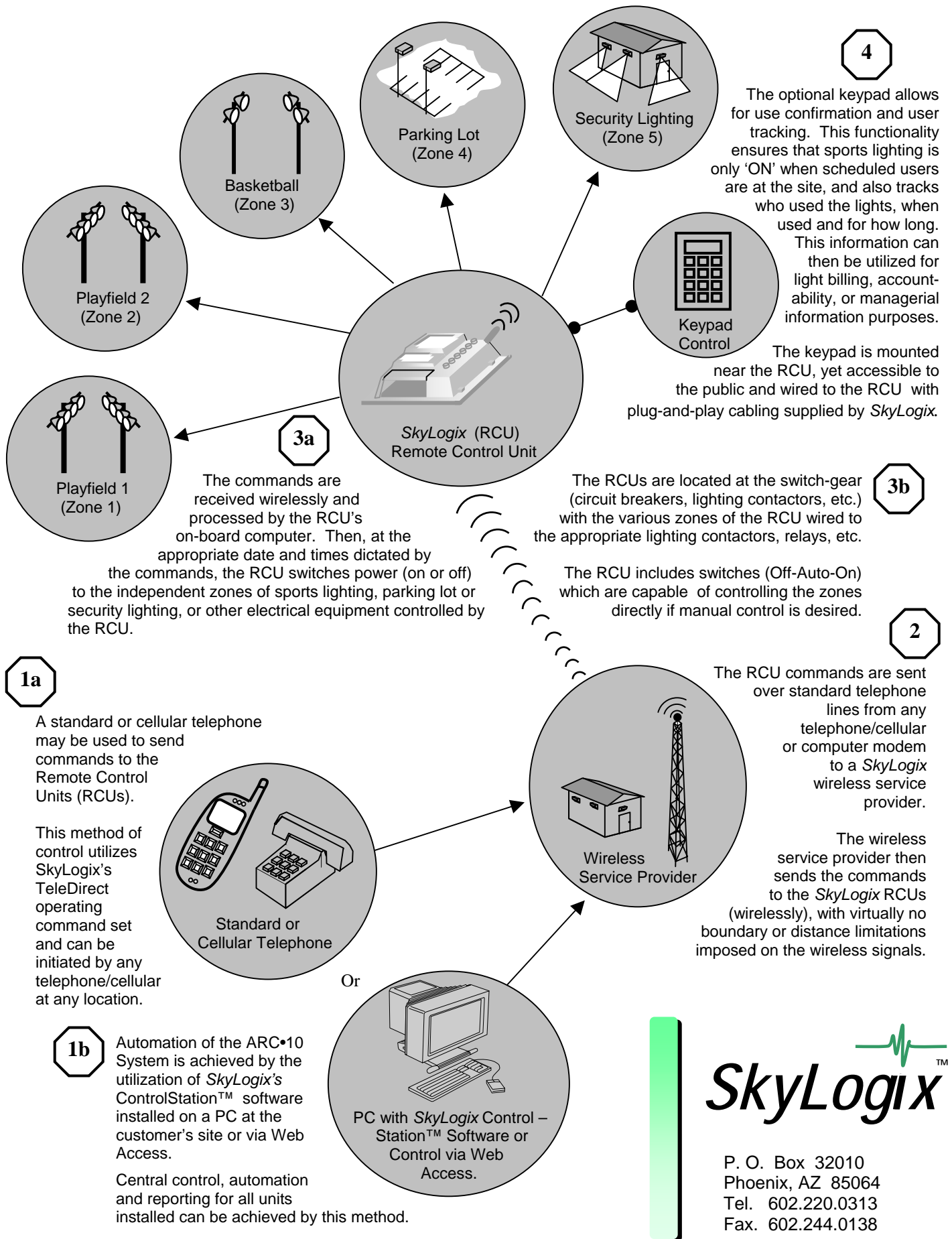

P. O. Box 32010  
 Phoenix, AZ 85064  
 Tel. 602.220.0313  
 Fax. 602.244.0138