

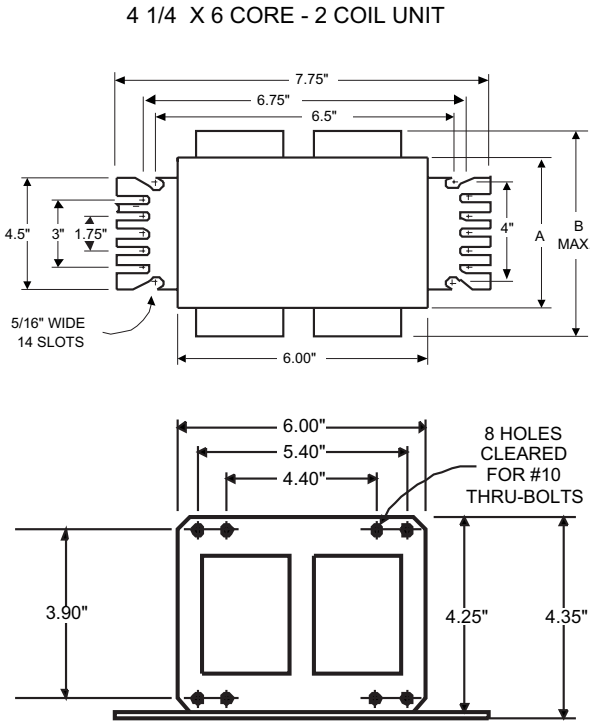

Metal Halide Lamp Ballast

Catalog Number 71A6792
For 1500W M48
60 Hz CWA
Status: Active

DIMENSIONS AND DATA



INPUT VOLTS	120	208	240	277
CIRCUIT TYPE	CWA			
POWER FACTOR (min)	90%			
REGULATION				
Line Volts	±10%			
Lamp Watts	±12%			
LINE CURRENT (Amps)				
Operating.....	13.5	7.80	6.75	5.85
Open Circuit.....	4.80	2.50	2.20	2.00
Starting.....	13.4	7.70	6.70	5.70
UL TEMPERATURE RATINGS				
Insulation Class	H(180°C)			
Coil Temperature Code	1029			
MIN. AMBIENT STARTING TEMP.	-20°F or -30°C			
NOM. OPEN CIRCUIT VOLTAGE	450			
INPUT VOLTAGE AT LAMP DROPOUT.....	80	140	160	185
INPUT WATTS	1605			
RECOMMENDED FUSE (Amps).....	30	25	20	15
CORE and COIL				
Dimension (A)	4.10			
Dimension (B)	6.10			
Weight (lbs.)	30			
Lead Lengths	12"			
CAPACITOR REQUIREMENT				
Microfarads	32.0			
Volts (min.)	525			
Fault Current Withstand (amps)	525			
60 Hz TEST PROCEDURES (Refer to Advance Test Procedure for HID Ballasts - Form 1270)				
High Potential Test (Volts)				
1 minute	2000			
2 seconds	2500			
Open Circuit Voltage Test (Volts)	405-495			
Short-Circuit Current Test (Amps)	7.40-9.00			
Secondary Current	9.80			
Input Current.....	14.8	8.30	7.80	6.70

Capacitor: MD3202-100

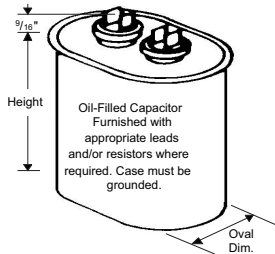

Capacitance: 32
 Dia/Oval Dim: 1.75
 Height: 5.3
 Temp Rating: 90°C

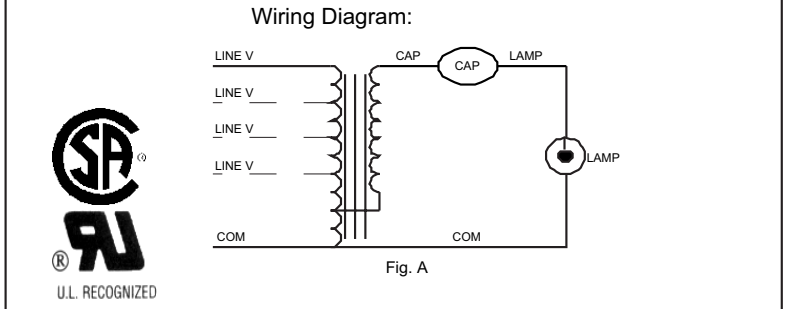

Ignitor: NA

This ballast does not require the use of an ignitor.

Ordering Information

Order Suffix	Description
500	Ballast with Oil-Filled Capacitor
510	Ballast w/Welded Bracket and Oil-Filled Capacitor
600	Ballast Only, No Capacitor
610	Ballast with Welded Bracket, No Capacitor

Data is based upon tests performed by Advance Transformer in a controlled environment and representative of relative performance. Actual performance can vary depending on operating conditions. Specifications are subject to change without notice.

ADVANCE TRANSFORMER CO.

O'HARE INTERNATIONAL CENTER · 10275 WEST HIGGINS ROAD · ROSEMONT, IL 60018
 Customer Support/Technical Service: Phone: 800-372-3331 · Fax: 630-307-3071
 Corporate Offices: Phone: 800-322-2086

09/11/97