

Installation Instructions

SLTC Series Arms and Brackets

WARNING! Due to a danger of damaging supply wires, any holes drilled into these poles, arms, or mounting brackets must be drilled BEFORE supply wire is pulled.

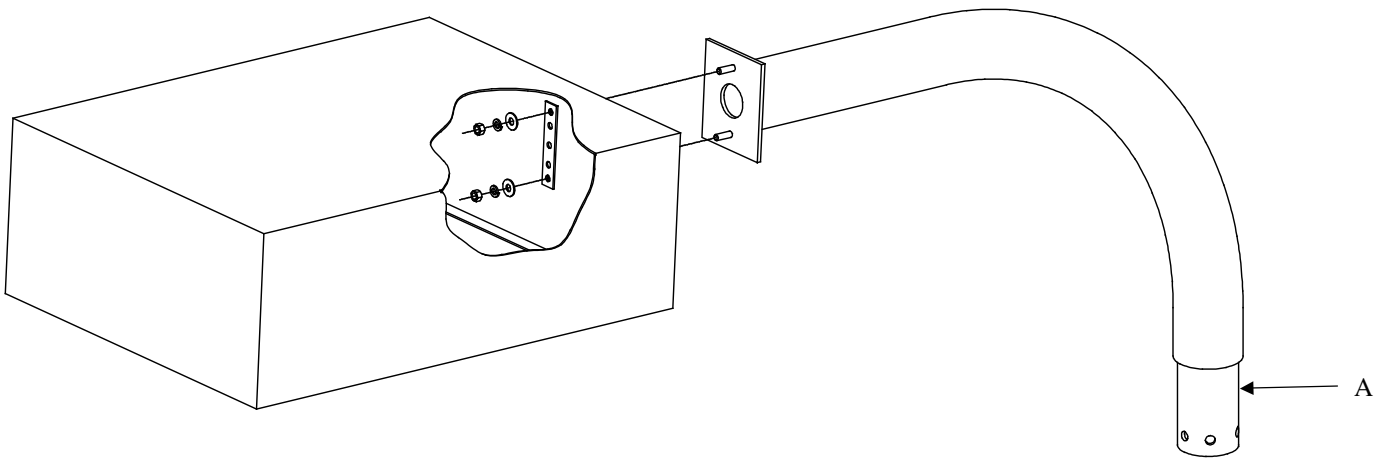

Single Arm Assembly (Not requiring SLTC mounting bracket)

1. Place arm tenon (A) into pole top (L) and loosely install three set screws (I).
2. Install fixture on arm (refer to instruction sheet supplied with fixture).
3. Rotate fixture to proper final alignment on pole and alternately tighten set screws to center arm in pole.
4. Using holes in pole as a guide, drill two 9/16" diameter holes through arm tenon at locations (J).
5. Install 1/2" bolt (K), lock washer, and nut at location (J).
6. Securely tighten all hardware.

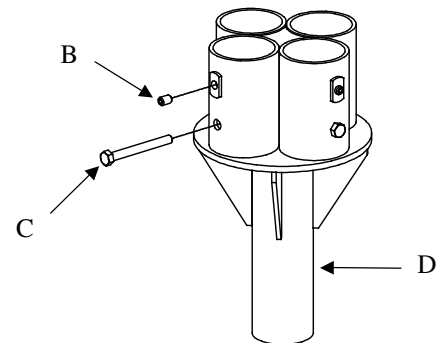

Dual and Quad Arm Assembly

1. Place mounting bracket tenon (D) into pole top (L) and loosely install three set screws (I).
2. Place arm tenons (A) into mounting bracket, align holes and install through-bolts (C) and set screws (B).
3. Install fixtures on arms (refer to instruction sheet provided with fixtures).
4. Rotate mounting bracket and fixtures to proper final alignment on pole and alternately tighten set screws to center mounting bracket in pole.
5. Using holes in pole as a guide, drill two 9/16" diameter holes through mounting bracket at locations (J).
6. Install 1/2" bolt (K), lock washer, and nut at location (J).
7. Securely tighten all hardware. Note: Setscrews (B) are for fixture leveling only.
8. Wrap shroud (E) around fitter bracket and bend tabs (H) through slots (G) to secure.
9. Bend tabs (F) down on top of mounting bracket top plate.

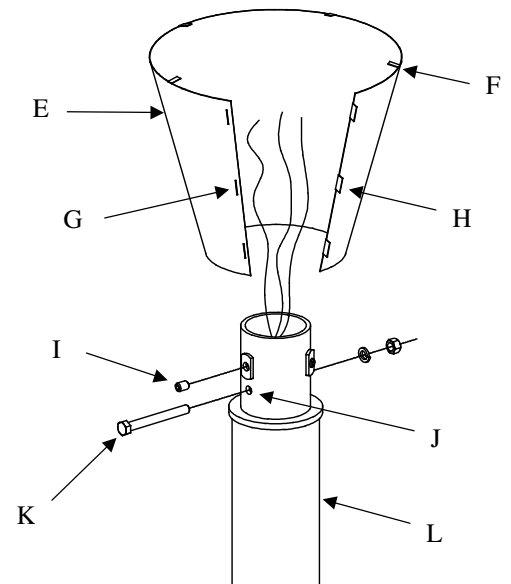

® Hubbell Lighting, Inc.
A Subsidiary of Hubbell Incorporated
2000 Electric Way
Christiansburg, VA 24073-2500
Ph: (540)-382-6111
Fax: (540)-382-1526

268-1227-9901